

TECHNICAL DATA				
	Dry air flow m ³ /h	Dry air condition* g/kg	Dry air available pressure Pa(s)	Dehumi- dification capacity kg/h*
RZ-81	2 800	2.8	>200	44
RZ-101	4 500	2.7	>200	71
RZ-102	7 000	2.7	>200	110

* At process air inlet 35°C 15,8 g/kg and cooler
1 as a pre-cooler with water in/out 6/12°C





COILS			
RZ-81			
	Heater*	Cooler 1**	Cooler 2***
Capacity [kW]	28	40	28
Liquid flow [l/s]	0.35	1.6	1.1
Liquid pressure drop [kPa]	6	28	16
RZ-101			
	Heater*	Cooler 1**	Cooler 2***
Capacity [kW]	45	67	46
Liquid flow [l/s]	0.55	2.7	1.8
Liquid pressure drop [kPa]	11	16	20
RZ-102			
	Heater*	Cooler 1**	Cooler 2***
Capacity [kW]	70	100	71
Liquid flow [l/s]	0.86	4	2.8
Liquid pressure drop [kPa]	4	21	24

* 80/60°C

** 6/12°C, 0% freezing additive. Cooler 1 as pre-cooler.

*** 6/12°C, 0% freezing additive. Cooler 2 as post-cooler.

Cooler 2 can also be placed as a pre-cooler.

ROTOR OPTIONS*	
	D-MAX – rotor for standard applications
	D-MAX H – bactericidal and hygienic
	D-MAX CI – 100% silicon free air
	SZCR – zeolite rotor for low dew points

* DST offers four unique rotors from Seibu Giken Co Ltd. D-MAX rotors are fitted as standard. Other rotors available as an option, see separate rotor brochure.

Seibu Giken DST AB has representatives in more than 40 countries world-wide

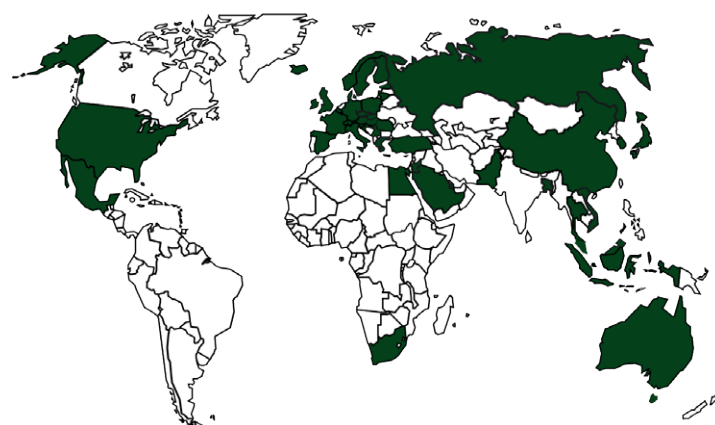

RZ FLEX DEHUMIDIFIERS

SEIBU GIKEN DST

Dehumidifying capacity
at 20°C / 60%RH

44 - 110 kg/h

Dry air flow

2 800 – 7 000 m³/h



Seibu Giken DST AB

Avestagatan 33 | SE-163 53 Spånga, Sweden

Telefon +46 8 445 77 20 | Fax +46 8 445 77 39

www.dst-sg.com | info@dst-sg.com

Seibu Giken DST

is certified according

to ISO 9001



GB 16.06



RZ FLEX - choose components according to your project

Simpler planning with one supplier

RZ FLEX consists of a modular system integrated with an RZ standard dehumidifier. Choose components such as precooling and postcooling, or integral temperature and moisture control. DST supplies a complete unit, which results in simpler planning, faster commissioning and unequivocal functional responsibility compared with systems built up via several different suppliers. All control functions are tested at the factory prior to delivery.

Low energy consumption is guaranteed thanks to the "Recusorb" dehumidification principle with integral heat recovery. With RZ FLEX, the combination of precooling and sorption dehumidification is optimal for every project. For applications with stringent hygiene requirements, we recommend a solution using dry cooling.

Module structure

The modules are made up using an aluminium framework. The panels are made from aluminium zinc (stainless steel is available as an option) with 50 mm double wall insulation, which also results in high levels of noise attenuation. All functional elements (see the example below) can be placed either before or after the dehumidifier.

Filter

RZ FLEX comes with integral bag filters, class F7, with centre latches fitted as standard or F9 as an optional extra.

Heating and cooling coils

Cooling coils are available with various outputs. Inspection hatches are placed before and after the coils. The fins of the cooling coil are treated with hydro fin, which prevents water carry-over and reduces the pressure drop.

Fans

A directly driven process fan with rear-facing blades requires minimal servicing and ensures low energy consumption. The chamber fan can be provided with a frequency converter (optional). The fan is mounted on runners. At low dewpoints, the fan can be placed before the dehumidifier as a compressive fan. The impeller is powder-painted.

Controls

Temperature and moisture control are available as optional extras, and are programmed and tested at the factory for faster startup in site. Sensors and controllers are supplied with cables for simple connection to the central electric unit.

Washable, highly efficient rotor

All DST dehumidifiers come with the D-MAX rotor fitted as standard. The D-MAX has a high dehumidification capacity and long service life, and it is washable and non-flammable. Another three rotors with unique properties are available as optional extras. [See the tab on the right and the DST rotor folder.]

Dehumidifier RZ FLEX

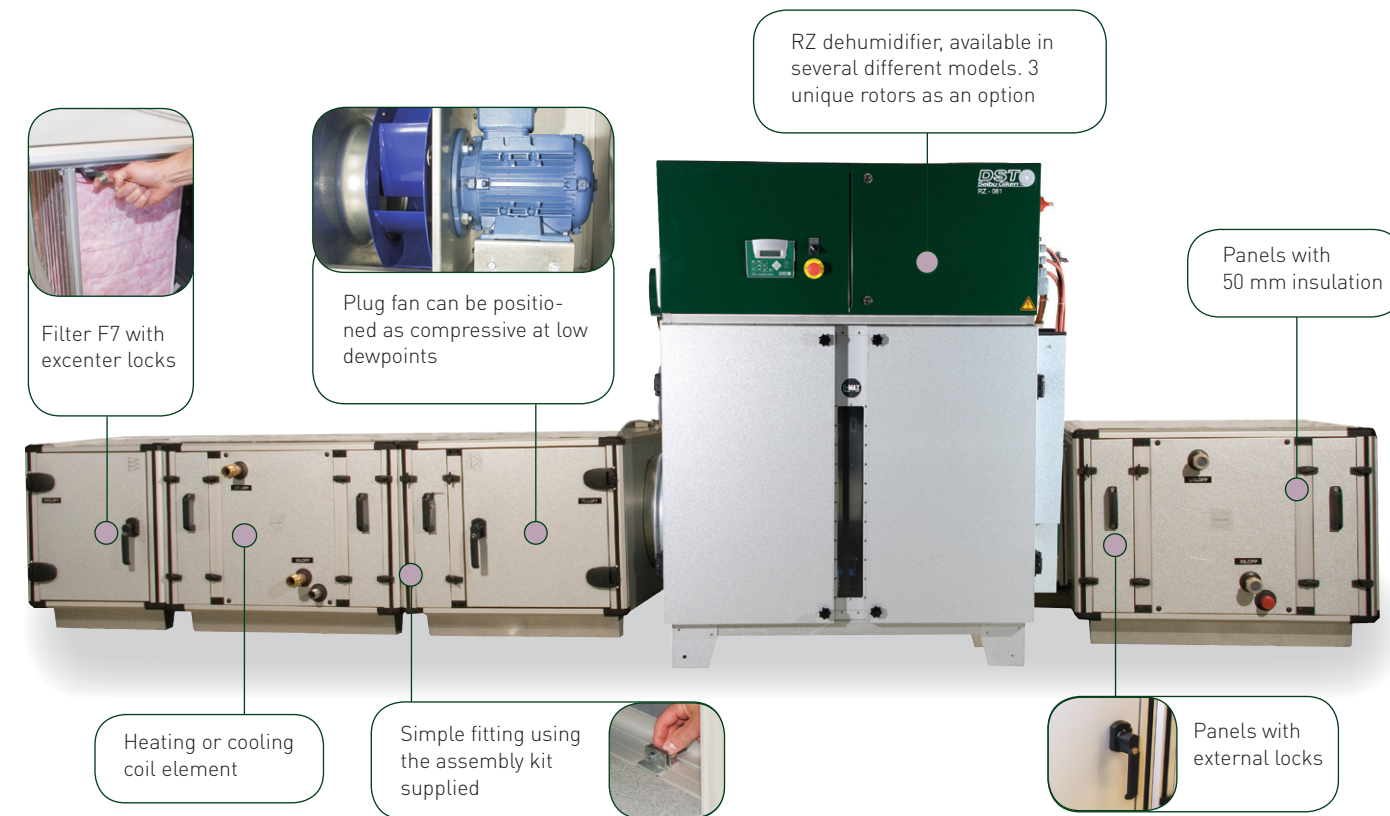

The drawing shows a configuration with all optional components

(The figure is not identical to photo above)

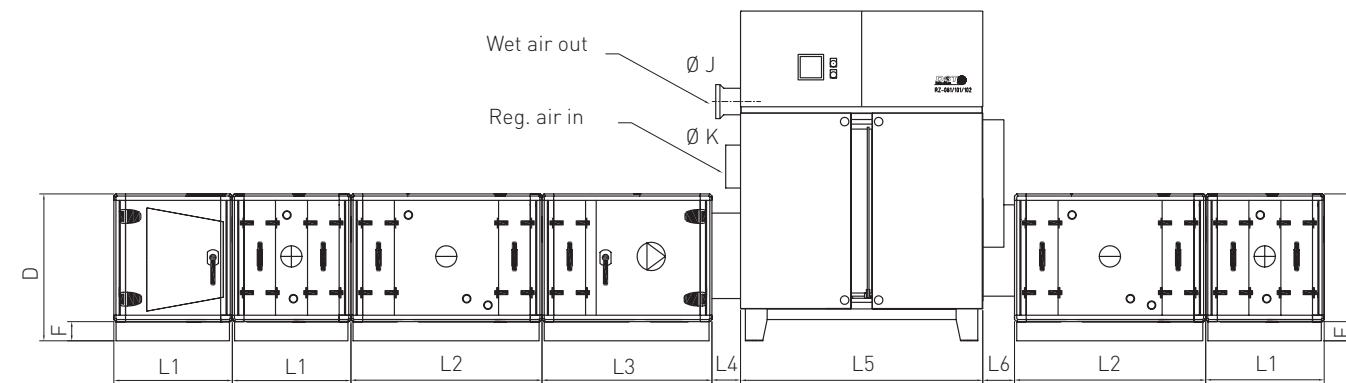

DIMENSIONS (MM)									
	A	B	C	D	E	F	G	H	I
RZ-81	800	500	960	691	1 550	90	820	1 130	370
RZ-101	1 100	600	1 255	813	1 850	90	1 017	1 465	510
RZ-102	1 100	700	1 255	990	1 940	90	1 080	1 517	600
	J	K	L1	L2	L3	L4	L5	L6	
RZ-81	160	200	558	900	800	135	1 140	150	
RZ-101	250	315	558	900	900	135	1 140	150	
RZ-102	315	400	558	900	1 000	881	1 240	150	

APPLICATIONS

RZ FLEX has been developed for applications requiring complete solutions for dehumidification, with moisture and temperature control. These units can also be fitted with special rotors for environments with special requirements; during pharmaceutical manufacturing, in the plastics industry, the manufacture of food and confectionery, the automotive industry, and others.

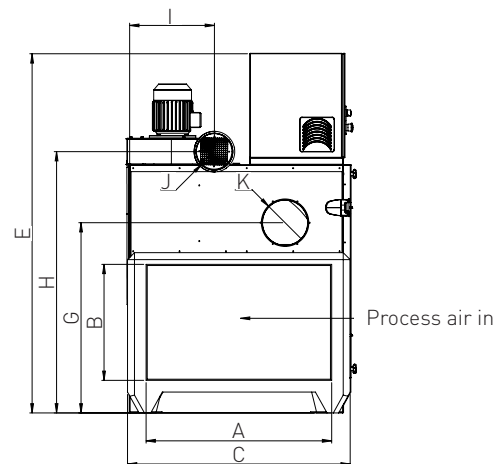
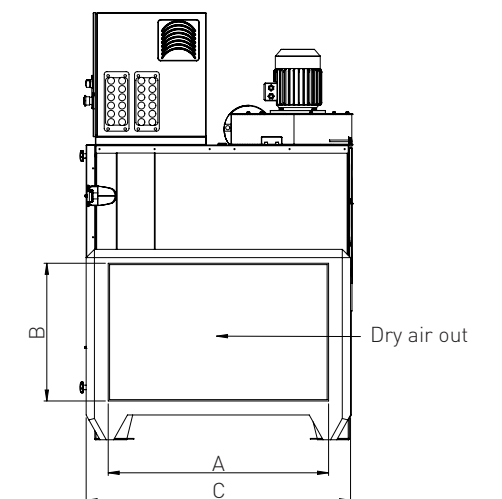

Subject to be changed without notice, see latest edition of data-sheet for RZ units.

Example of configuration with options

DST provides pre-, and post treatment coils complete with temperature control, and all from a single supplier. Contact your nearest DST representative for further information.

